

# NSB 210FT *Red Battery*®

Long float life at elevated temperatures



*Red Star Technology*® uses pure lead plates to deliver **exceptionally long float life even at elevated temperatures.**

- Pure lead AGM technology delivers long float life for telecom applications even at elevated temperatures
- 15 year float life at 20°C (68°F)
- EUROBAT design life definition: Long Life (12+ years)
- High energy density
- Operating temperature range: -40°C to +65°C (-40°F to 149°F)
- State-of-the-art automated manufacturing ensures consistency and reliability
- Advanced 3 stage terminal design to ensure leak-free operation - female M8 brass terminals provide maximum performance
- 2 year shelf life at 25°C (77°F)
- High modulus Polyphenylene Oxide (PPO) plastic materials designed to withstand extended elevated operating temperatures and maintain high battery compression essential for reliable operation
  - Non-halogenated, thermally sealed plastic casing
  - Flame retardant (UL 94 VO) and LOI of at least 28%
- Integral handles and front access terminals ensure ease of installation and maintenance
- Approved as non-hazardous cargo for ground, sea, and air transport - DOT 49CFR173.159(d), (i) and (ii)

Visit our website to find out more [www.northstarbattery.com](http://www.northstarbattery.com)



# NSB 210FT Red Battery®

## Nominal Technical Specifications



### Electrical

|                              | International Standard 20°C (68°F) | North American Standard 25°C (77°F) |
|------------------------------|------------------------------------|-------------------------------------|
| 8 hour capacity to 1.75 VPC  | 207 Ah                             | 210 Ah                              |
| 10 hour capacity to 1.80 VPC | 209 Ah                             | 212 Ah                              |
| Float Voltage                | 2.29 +/- 0.02 VPC                  | 2.27 +/- 0.02 VPC                   |
| Nominal Voltage              | 12 V                               |                                     |
| Impedance (1kHz)             | 2.7 mΩ @ 25°C (77°F)               |                                     |
| Conductance                  | 2,038 S                            |                                     |
| Short Circuit Current        | > 6,000 A                          |                                     |

### Dimensions

|        |                  |                 |                    |
|--------|------------------|-----------------|--------------------|
| Height | 328 mm (12.9 in) | Weight          | 66 kg (145 lbs)    |
| Width  | 126 mm (4.96 in) | Terminal        | Female M8 x 1.25   |
| Depth  | 560 mm (22.0 in) | Terminal Torque | 8.0 Nm (71 in-lbs) |

### Ah Capacity Ratings @ 25°C (77°F)

| Capacity Discharge / hours | 1    | 2    | 4    | 8    | 10   |
|----------------------------|------|------|------|------|------|
| Capacity @ 25°C / Ah       | 156  | 176  | 195  | 209  | 212  |
| End of Discharge / VPC     | 1.70 | 1.75 | 1.75 | 1.75 | 1.80 |

### Drawings

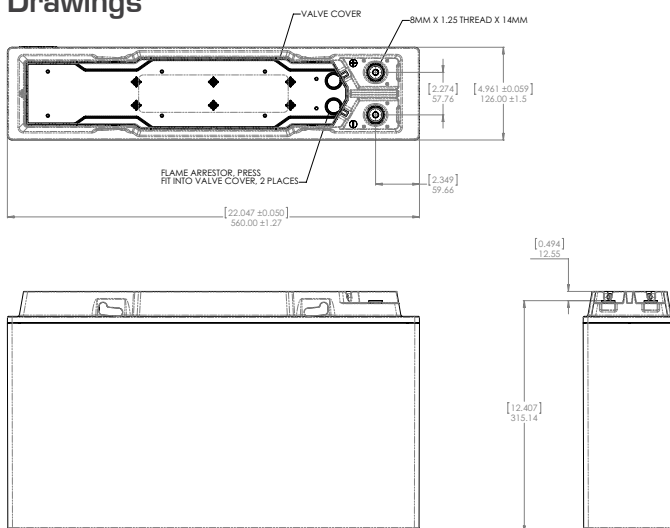

All NorthStar batteries are compliant with: Telcordia SR4228, IEC 60896; Bellcore GR-63-Core, Issue 1; British, German, and Russian telecom standards; UL approved. NorthStar is registered to ISO 9001 and ISO 14001.

#### NorthStar Americas

NorthStar Battery Company LLC  
4000 Continental Way  
Springfield, MD, 65803,  
United States of America  
info@northstarbattery.com  
Tel: +1 417 575 8200  
Fax: +1 417 575 8250

#### NorthStar Europe

SiteTel Sweden AB  
Staffans Väg 8  
SE-192 07 Sollentuna,  
Stockholm, Sweden  
europe@northstarbattery.com  
Tel: +46 8 410 102 00  
Fax: +46 8 638 06 00

#### NorthStar Middle East, Africa

SiteTel Sweden AB JTL Branch  
Office 702, Saba 1 Tower  
Jumeirah Lake Towers, Dubai  
United Arab Emirates  
mea@northstarbattery.com  
Tel: +971 4 423 8060  
Fax: +971 4 423 8061

#### NorthStar Asia-Pacific

NS Asia Pacific Sdn. Bhd.  
B2-3A-13A, Solaris Dutamas  
No. 1, Jalan Dutamas 1, 50480  
Kuala Lumpur, Malaysia  
asia@northstarsitetel.com  
Tel: +60 3 6419 0711

[www.northstarbattery.com](http://www.northstarbattery.com)

